

### 1 POWER jack and switch.

A battery or wall power supply may be used to power the bitRanger. Plugging the supply into the power jack will disconnect the battery. Battery: Install a 9volt battery into the open battery compartment on the bottom of the unit. Power supply: Use a 9 or 12VDC 100mA (or more) negative ring supply. 2.1mm pin - 5.5mm barrel.

### 2 AUDIO

Onboard speaker and stereo headphone output. Plugging a cable into the headphone output will disconnect the speaker.

### 3 VCO (voltage controlled oscillator) knob.

Audio tone generator. Turn the knob to change the pitch

### 4 HFO (high frequency oscillator) knob.

Master sync oscillator. Turn the knob to set master pitch. The VCO will sync to this pitch creating harmonic steps and wave shaping effects when adjusted.

### 5 MODE switches.

Change the oscillator wave shape by setting both mode switches.

- AI. = simple tone
- BI. = complex tone
- All. = noisy tone
- BII. = digital noise

Each mode reacts differently to the master sync oscillator and the data modulation setting.

### 6 DATA MODULATION switch.

Apply the LFO to a wave shape processor. Speed of modulation is set with the LFO and CLK OUT switch (On right side panel). The effect differs in each mode.

- AI. = pitch modulation
- BI. = wave shape inversion
- All. = slight wave shape randomization
- BII. = noise randomization

### 7 LFO (low frequency oscillator) knob.

Controls the rate of sound modulation when the data mod switch is on

(and more...discussed later). The LFO range is set with the LFO RATE switch.

### 8 BEND sockets [input/output].

Plug light sensors (included) into any of the bend sockets to control each oscillator with light. Plug in other stuff. See what happens.

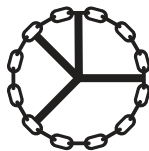
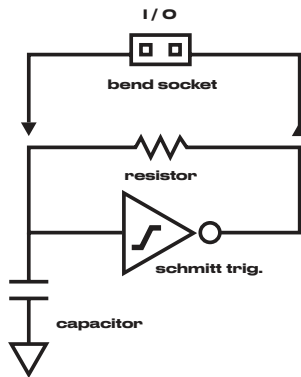

TECH NOTE Each oscillator is based on a common schmitt trigger (inverter), resistor, capacitor architecture. The bend socket is connected to the input and output of the schmitt trigger. Connecting resistors(like the LDR) to these points will change the pitch of the oscillators. Lots of other effects can be achieved by connecting other components and signals to these sockets.

# GETTING STARTED

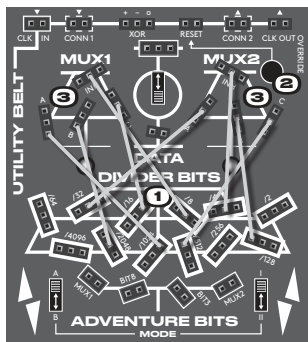
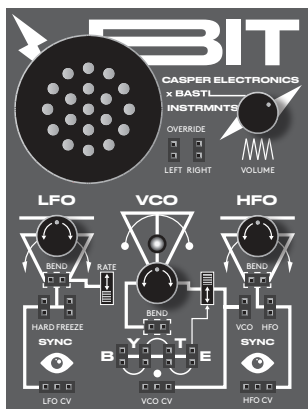

## Patch outlined sockets into non-outlined sockets to create sequences and other audio hijinks.

outline = output  
no outline = input  
dashed line = input or output

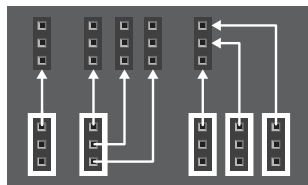

## 1 DIVIDER BITS [outputs]

The divider sockets output 12 clocks of different speeds which are subdivisions of the LFO.  
These outputs can be patched to any of the input sockets to create sequenced patterns.

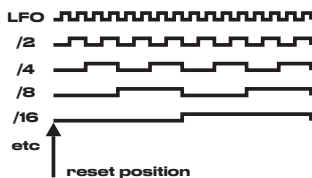

## 2 RESET button

Resets all of the divider output clocks.

## 3 MUX1&2 (multiplexer) [inputs]

Wave shape and pitch modulation.  
Each Mux has 4 inputs: A, B, C and INH (inhibit=mute).  
Patching a square wave (divider bit outputs etc) to any of these inputs will create changes to the wave shape of the audio oscillator and sends two different versions of that signal to the left and right outputs of the headphone jack.  
The effect varies from subtle to extreme depending on the MODE setting.

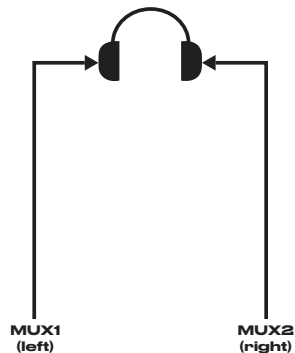

## TIPS

- Wear headphones (!) for a stereo experience.
- Play with the oscillator pitch and range settings.
- Plug multiple divisions into the same input socket.
- If nothing crazy is happening, plug in more cables.
- Keep plugging in cables!

## &TRICKS

- Build the example patch on the left and patch a bit from the adventure bits section into the center VCO CV input socket.

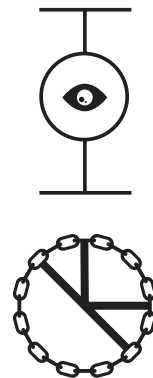

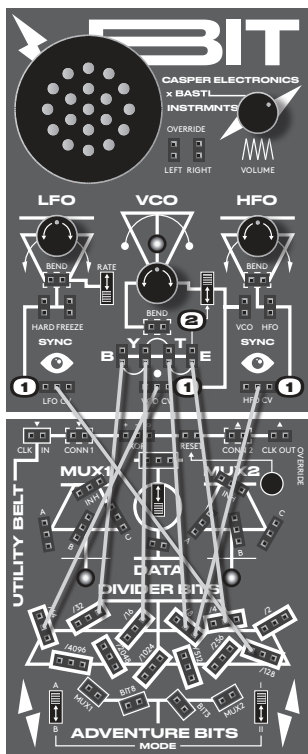

**Use the bits as voltage sources to control the frequency of the three voltage controlled oscillators.**

### 1 CV (control voltage) [inputs]

The inputs in each of these sockets are "weighted" from left to right, meaning that the left most input (per socket) has the weakest effect while the rightmost has the strongest.

**LFO:** Change the rate of the LFO. Higher voltage = higher rate. Works best with low frequency signals (such as /64 and up from the divider bit section).

**VCO:** Change the pitch of the VCO. Higher voltage = higher pitch. This is a slewed input meaning that changes to the pitch will be gradual.

cv input



pitch change

**HFO:** Change the pitch of the HFO. Higher voltage = lower pitch. The depth of pitch modulation depends partly on the initial setting of the HFO pitch knob. For instance the depth will be much greater when the knob is in the middle than it is when all the way up or down.

### 2 BYTE sockets [inputs] and switch

Plug multiple bits into the BYTE sockets to create stepped voltages that can then be applied to the VCO (via the BYTE switch) and/or the CV output jack (right side panel) to control external equipment. The BYTE switch turns BYTE CV modulation of the VCO on (up) and off (down).

### TIPS

- Try the example patch pictured to the left. Insert jumpers one at a time to get an idea how they work.
- Use the longer divisions (/128 and up) to create patterns that change over long periods of time.
- Patch the 4 cables (as shown) into the BYTE socket to get a ramped arpeggio like the one shown in the drawing below. Switch the bits around to get different patterns.
- The BYTE input jacks can also work as outputs when you have several

bits connected. Patch a cable into any available spot in the BYTE section and connect to the different oscillator CV input sockets or the BEND sockets.

- The left terminal of each BEND socket functions as a crude pitch CV input. The results are unpredictable but can be very effective in different scenarios.

### &TRICKS

- Patch /32 to MUX1 INH and /4 to MUX2 INH.
- Connect the MUX1&MUX2 output sockets from the adventure bits section into the VCO CV and LFO CV inputs.
- Patch more cables from the divider bits to the MUX and CV inputs and observe the changes in the sound and behavior.

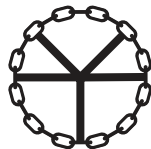

**TECH NOTE** The byte section is a standard R2R digital to analog converter. When multiple bits are fed into the R2R you get a stepped voltage at the output.

# CV PATCHING

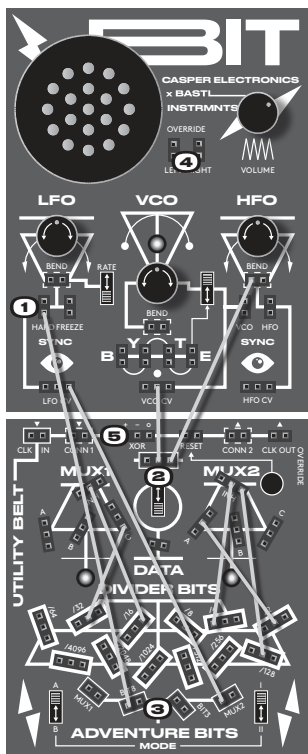

**Patching techniques for the adventurous user. These features are most effective when integrated into complex patches that incorporate the MUX1&2 sections and CV sockets.**

### LFO SYNC sockets [inputs]

**LFO Hard sync** resets the LFO cycle when it receives a positive signal. This works well with the DATA output (2) and ADVENTURE BITS (3). Read section 3 below before using the adventure bits.

**LFO Freeze** holds the LFO low when it receives a positive signal. This is intended primarily for use with external signals. Because the signal causes the LFO to freeze it is very likely that patching a signal from within the bitRanger will cause the whole circuit to freeze and make no sound.

### 2 DATA socket [output]

This socket outputs a combination of the two MUX outputs as a stepped voltage which is fed to the data input of a shift register which is then processed through MUX 1&2. This can be used as a CV source for external equipment or as a complex modulation source when patched into the oscillator CV and SYNC inputs.

### 3 ADVENTURE BITS sockets [outputs]

The adventure bits section outputs irregular patterns of bits. These serve as a source of irregularity in contrast to the regular divisions from the divider bits section.

The bit patterns are "programmed" by patching bits (from the divider section or external equipment) into the MUX1&2 section input sockets. Therefore it's necessary to patch bits into the MUX ins to create useful patterns at the outputs. The two LEDs (below MUX1&2) indicate the outputs of MUX1&2 adventure bits.

### 4 LEFT RIGHT OVERRIDE sockets [inputs]

Bits patched to these sockets will override the internal routing of MUX1 to the left headphone output and MUX2 to the right.

### 5 XOR GATE socket [input and output]

The XOR gate can be used as a binary buffer or an inverter with bit controlled inversion. This can be useful for utility purposes as well as experimental patches.

The XOR gate has 3 terminals: + (non inverting), - (inverting) and O (out). Bits patched to the + terminal will appear at the O terminal unchanged.

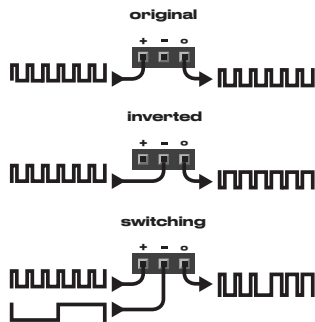

### TIPS

- The impact of patching the DATA and ADVENTURE BITS will change depending on the MODE switch settings. Make sure to try other modes.
- Plug multiple outputs into the same input as shown in the patch to the left. This will create irregular bit patterns.
- Irregular and noisy sequences can be created by patching bits into the LFO SYNC and CV sockets.



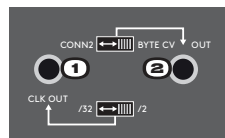
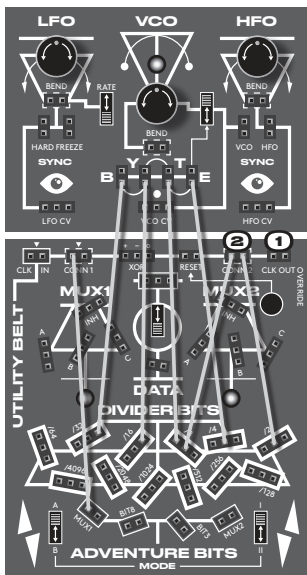

### 1 CLK OUT (clock out) jack & switch

This jack outputs a 5 volt square wave controlled by the LFO. Use the CLK OUT switch to determine if the output is the LFO divided by 2 or divided by 32. The CLK OUT OVERRIDE input socket can be used to override the switch and send alternate signals to the output.

### 2 CONN2 /BYTE CV OUT jack, switch and socket

The CONN2/BYTE CV OUT switch sets the functionality of the 3.5mm jack. BYTE CV OUT mode = BYTE voltage routed to jack. Bits patched to the BYTE section will be converted to stepped voltages which can be used to modulate voltage controlled parameters. CONN 2 mode = jack is connected to the zener diode protected CONN 2 socket. In this mode the CONN 2 jack can function as an input OR output. Incoming signals above 5volts will clip at 5volts. Below 0volts will clip at 0volts. CONN 2 mode = jack is connected to the zener diode protected CONN 2 socket.

**Patch any of the outputs of the bitRanger to a modular synthesizer or anything else that receives voltages... analog keyboards, home made synthesizers, arduinos etc.**

**MODULAR SYNTHESIZER  
OUT FROM BIT R.**

## EXAMPLES

### Algorithmic Sequencer:

- Set CONN2/BYTE CV switch to BYTE CV mode.
- Patch multiple bits from the divider section to the BYTE sockets.
- Patch the BYTE CV OUT jack to the CV input of a module. Works especially well as control voltage for a VCF.

### Swing Beat Generator and Rate Multiplier:

- Plug external clock into the CLK IN jack.
- Plug CLK OUT jack into the trigger or gate input of a module.
- Set the LFO rate switch low and adjust the LFO knob.

### Patching CVs and Gates Out of the BitRanger:

- Set the CONN switches to CONN mode. Either will work but lets use CONN1.
- Patch any of the bitRanger output sockets to the CONN1 socket.
- Plug a cable from the CONN1 jack to an input jack on your modular synth. Use the output bits (divider, adventure, data) to send trigger events such as clocking a sequencer. Use CV outputs like the BYTE section or input sockets with multiple outputs connected to them to control variable parameters like filter cut or oscillator pitch.

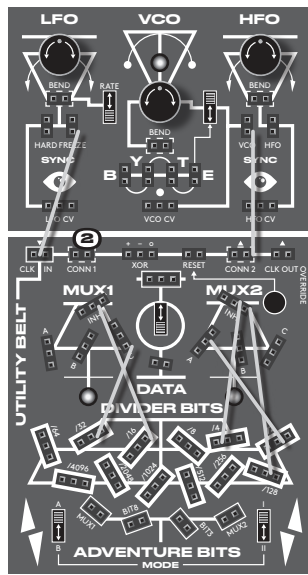

### 1 CLK IN (clock in) jack

Use an external signal to reset the LFO. Interesting sync effects including swing and rate multiplication can be achieved by adjusting the LFO knob.

### 2 CONN1/VCO CV IN jack, switch and socket

The CONN1/VCO CV IN switch sets the functionality of the 3.5mm jack. VCO CV IN mode = voltage plugged to the jack is applied to the CV input of the bitRanger VCO. CONN 1 mode = jack is connected to the zener diode protected CONN 1 socket. In this mode the CONN 1 jack can function as an input OR output. Incoming signals above 5volts will clip at 5volts. Below 0volts will clip at 0volts.

## EXAMPLES

### CV Pitch Control:

- Set CONN1/VCO CV IN switch to VCO CV IN mode.
- Plug the CV output of any module into the VCO CV IN jack. The external voltage will control the pitch of the VCO.

### Syncing to an External VCO:

- Set CONN1 to CONN mode.
- Plug the output of a VCO into the CONN1 jack
- Patch a jumper from the CONN1 socket to the VCO sync input socket.
- Try syncing the HFO and LFO as well. Set the LFO rate switch low when syncing to an LFO and high when syncing to an audio range oscillator.

### Patching CVs and Gates into the BitRanger:

- Set the CONN1 switch to CONN mode.
- Plug the desired signals (CV, audio, gate, trigger) into the CONN1 jack
- Patch a jumper from the CONN sockets to an input socket on the bitRanger. If the external signal is an audio or CV signal try connecting to any of the CV input sockets. If the external signal is a gate try connecting it to the MUX inputs or any other input. It will work with CV inputs as well.

### Patching External Clocks into the LFO Freeze Socket:

- Patch divider bits into the MUX and/or BYTE sections to make a sequence.
- Plug a low frequency square wave from the modular synth into the CLK jack on the bitRanger.
- Patch a jumper from the CLK IN socket to the LFO FREEZE socket.
- The sequence will freeze (hold) every time the incoming square wave goes high.

**MODULAR SYNTHESIZER  
IN TO BIT R.**

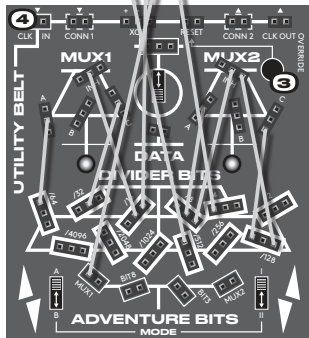
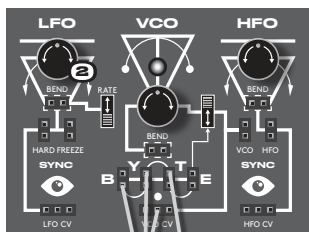

### 1 CLK IN (clock in) jack

Sync the LFO with an external clock.

### 2 LFO knob and switch.

An external clock plugged into the CLK IN jack will reset the LFO cycle



with every clock pulse. This allows interesting clock syncing effects to be achieved like clock rate multiplication and swing. Set the LFO rate low and turn the LFO knob to explore these effects.

### SYNC



### SWING



### MULTIPLICATION



### 3 RESET button and socket [input]

Press this button to reset the divider and therefore any sequence that the divider is controlling (like in the patch shown to the left). This is useful for resetting your sequence if it falls out of phase with the down beat of the drum machine sequence.

### 4 CLK IN (clock in) socket [output]

This socket simply passes along the signal plugged into the CLK IN jack. This allows you to send this clock to other destinations.

### TIPS for SLAVE

- Try using irregular clocks to sync the LFO. This is possible with drum machines that allow single drum triggers to be output or with a wide range of trigger sequencers like the Bastl KnitRider.
- Patch the CLK IN socket to the LFO FREEZE socket. Whenever the FREEZE socket receives a positive signal it will hold the LFO low. This can be especially interesting if you switch the LFO rate HIGH.
- Adjusting the LFO rate (when synced to an external clock) will allow you to tune into various swing and rate multiplication effects. But in doing so it is common that

the sequence controlled by the divider bits (which are clocked by the LFO) will go out of phase with the down beat of the drum machine sequence. Use the reset button to bump your sequence back into phase.

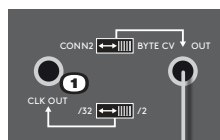

### 1 CLK OUT (clock out) jack and switch

Connect the CLK OUT jack to the clock input of any drum machine with a clock input such as the Korg VolcaBeats or Teenage Engineering PO12. The LFO sets the clock speed. The CLK OUT switch sets if the clock is divided by 2 or 32.

### 2 CLK OUT OVERRIDE socket [input]

Bits patched to this socket override the setting of the CLK OUT switch and are routed directly to the CLK OUT jack. This is useful if you wish to clock external devices with a division other than /2 or /32.

### TIPS for MASTER

- Plug several bits from the divider section into the clk out override socket to get uneven clock patterns.
- You will often get the best results if the CLK OUT switch is set to /2 when the LFO rate is LOW and /64 when the LFO rate is HIGH.

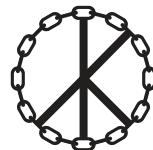
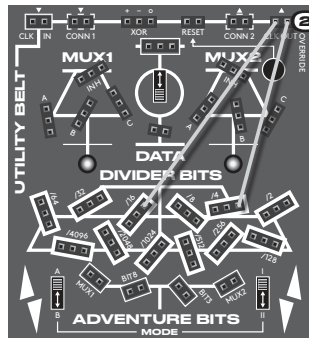
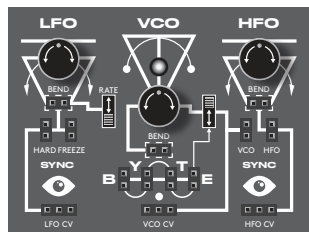

DRUM MACHINE

# BIT R. AS SLAVE

DRUM MACHINE

# BIT R. AS MASTER

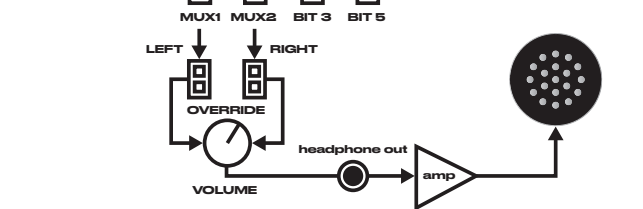
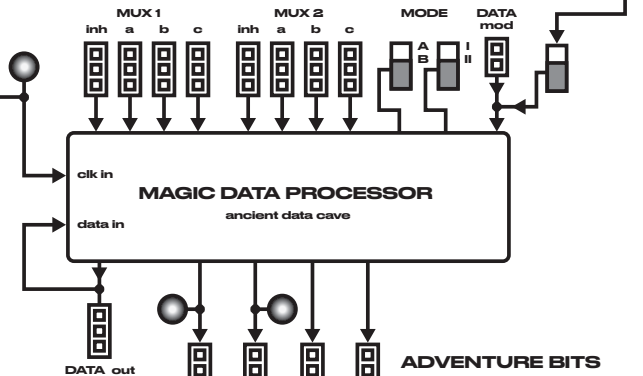
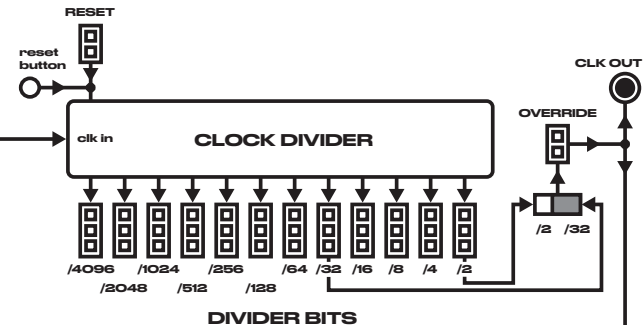
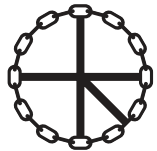
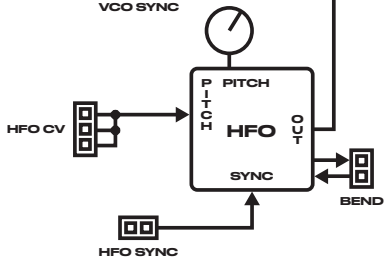
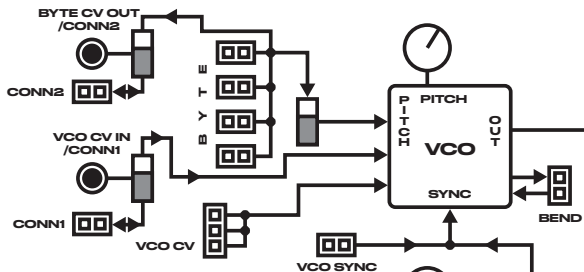
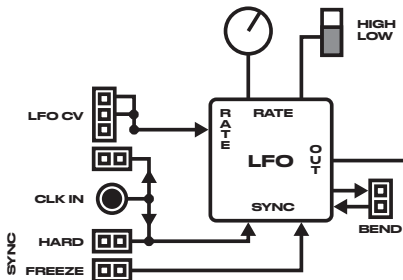

# BLOCK DIAGRAM





# 10'S SOUND ALCHEMY SYNAPSIS

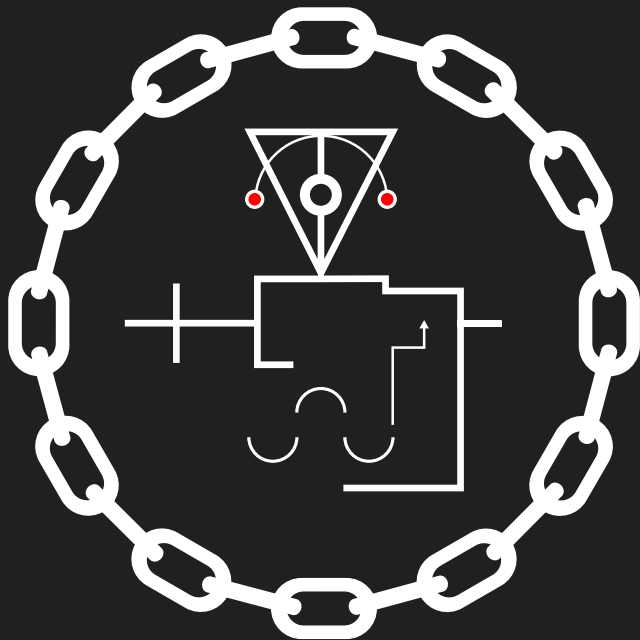

BASTL INSTRUMENTS  CASPER ELECTRONICS

## FEATURES

- LFO clock oscillator for rhythmical modulation
- VCO oscillator is synced to the HFO oscillator
- 4 modes of operation selectable by 2 switches
- built in speaker with volume control
- 9V DC center positive power supply input
- 9V battery compartment from the bottom
- <20mA power draw on headphones, <60mA with speaker (minimum 20 hours on battery)
- On/Off switch
- expansion connector
- package includes 3 photo resistors – make your oscillators respond to light by plugging these into the Bend socket

## PATCHBAY

- 118 jumper cable patch points
- each oscillator has 3 differently slewed CV inputs, sync inputs, rate knob and bend points
- Divider Bits section – use clocks at different speed to create patterns
- Adventure Bits section adds irregular rhythmical elements
- MUX 1 and MUX 2 input sections to modulate data loops and waveforms
- stereophonic output from MUX 1 and MUX2 sections
- BYTE CV section is R2R DAC converter which takes bits and converts them to CV

- DATA modulation section switch adds more flavor
- Utility Belt section adds advanced features
- Left and Right audio override section

## EXTERNAL CONNECTIVITY

- 3.5mm stereophonic headphone output
- Clock Input to sync the LFO oscillator
- Clock Output with selectable LFO division (2 or 32)
- CV Output from the BYTE DAC section
- CV Input for the VCO
- CV In and CV Out connectors can be routed to dedicated patch points on the patchbay

# B

# R



## ABOUT

**The bitRanger is a patchable analog logic computer which sculpts sonic worlds ranging from data noise to melodic arpeggios. Extensive connectivity makes it so flexible that it can connect to almost anything: CV control its unique sound, sync it with drum machines and sequencers or use it as an algorithmic CV/GATE pattern generator.**



**THE BITRANGER**